

Peninsular Mill Type Cylinder Sizing Chart

- PRINT this Blank Template Page
- PRINT the APPLICATION DATA SHEET (SCROLL DOWN)
- FILL IN the Required Information on BOTH PAGES
- FAX BOTH PAGES to Peninsular at (586) 775-4545

Head Rectangular Flange MF1 Mount

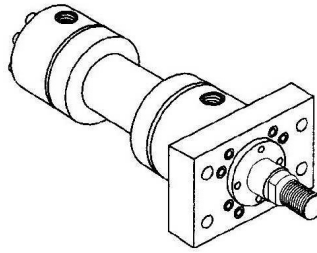

Date Submitted: _____ No. of Pages _____
 Name: _____
 Company: _____
 Phone: _____
 Fax: _____
 Email: _____

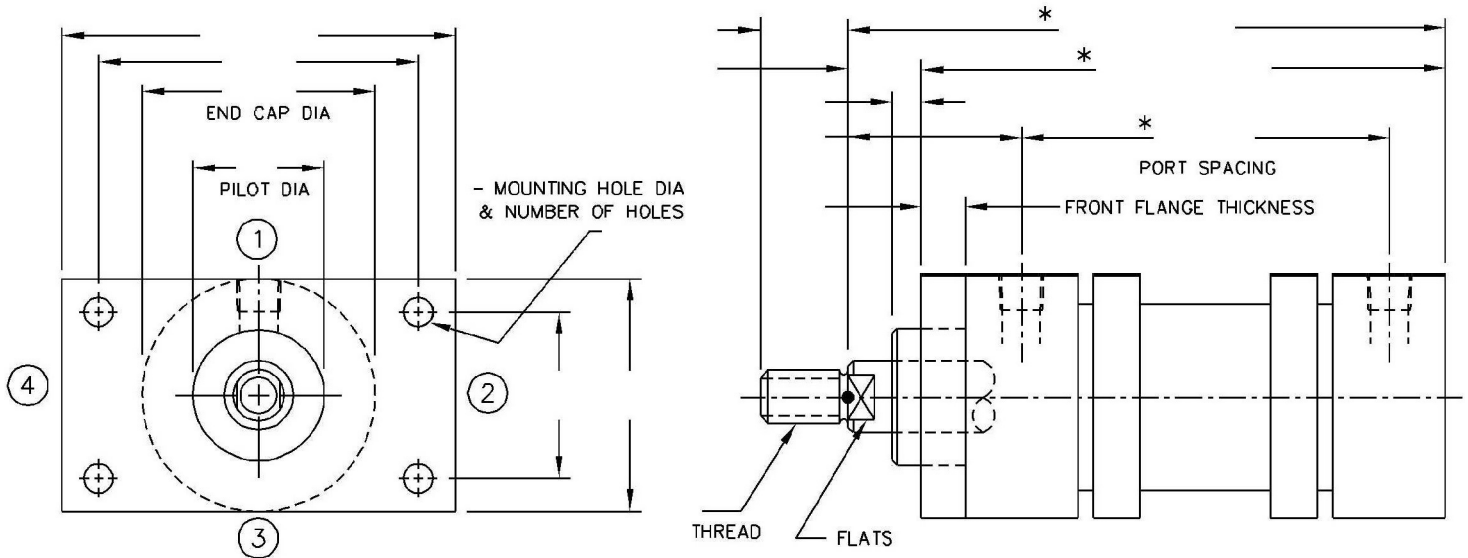

ABOVE: Fill in actual Cylinder Dimensions. **BELOW:** Check ALL Applicable Boxes & provide ALL INFORMATION to best describe the Cylinder

- AIR CYLINDER - Indicate Working Pressure: _____
 HYDRAULIC CYLINDER - High Pressure
 HYDRAULIC CYLINDER - Low Pressure

If Hydraulic - Indicate Working Pressure: _____

If Hydraulic - Indicate Maximum Rated Pressure: _____

If Hydraulic - Indicate Fluid Type: _____

Is the Cylinder an "INCH" Cylinder? Yes No

Is the Cylinder METRIC? Yes No

if METRIC, specify Standard: _____

SAFETY FACTOR Required: _____

End Cap STYLE: Welded Threaded Snap Ring

Cylinder TUBE MATERIAL: _____

Cylinder END CAP MATERIAL: _____

Are GREASE FITTINGS Required? Yes No

BORE Size: _____ STROKE Length: _____

PISTON ROD DIAMETER: _____ PISTON ROD THREADS: Male Female Other (Describe): _____

Specify PISTON ROD THREAD DIAMETER, PITCH & LENGTH (example: 3/4" - 16 x 1.125") : _____

PORT THREAD TYPE: NPT SAE (O-Ring) SAE Four Bolt Flange PORT THREAD SIZE (Specify): _____

Does the Cylinder have OPTIONAL CUSHION(s)? No on BOTH End Caps the FRONT END CAP Only the REAR END CAP Only

Indicate Existing Cylinders MANUFACTURER & MODEL NUMBER : _____

Is a Cylinder ACCESSORY Required? (ex. a Rod Clevis) : No Yes (indicate the type of Accessory _____ & provide Dimensions on Page 10)

Indicate any other Special Cylinder Features if applicable. If available, provide Sketches, Engineering Drawings and Photographs of the Cylinder. If applicable, indicate the Mode of Cylinder Failure, Harsh Environmental Factors, Electronic Positioning Devices or any other Pertinent Information regarding the existing Cylinder. For any questions, please call Peninsular Inside Sales at 1-800-526-7968.

Referencing the diagram below, indicate the **SIDE LOCATION #** for PORTS and/or Optional CUSHION ADJUSTMENT SCREWS for both the FRONT & REAR End Caps

FRONT End Cap

• The PORT (Hydraulic or Air) is located on FRONT End Cap SIDE LOCATION #s: _____

• The CUSHION ADJUSTMENT SCREW (an Optional Feature) is located on FRONT End Cap SIDE LOCATION #: _____

REAR End Cap

• The PORT (Hydraulic or Air) is located on REAR End Cap SIDE LOCATION #s: _____

• The CUSHION ADJUSTMENT SCREW (an Optional Feature) is located on REAR End Cap SIDE LOCATION #: _____

End Cap Port / Cushion Adjustment Screw SIDE LOCATION # Diagram

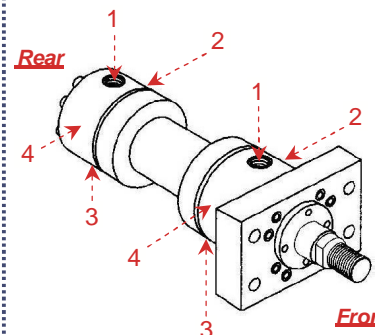

Always view the Cylinder through the Rod End from the Front End Cap side of the Cylinder



**PENINSULAR
CYLINDER CO.**

APPLICATION DATA SHEET

for Peninsular Mill Type Cylinders

- *PRINT this APPLICATION DATA SHEET*
- *FILL IN the Required Information on BOTH PAGES*
- *PRINT the SIZING CHART for the cylinder you need*
- *FAX BOTH PAGES to Peninsular at (586) 775-4545*

BELOW: Check ALL Applicable Boxes & provide ALL INFORMATION to best describe the Cylinder

Date Submitted: _____	Type of Business: _____
Company Name: _____	Contact Name: _____
Address: _____	Title: _____
City: _____ State: _____ Zip: _____	Telephone: _____ Fax: _____
Country: _____	Email: _____
CHECK ONE: Distributor <input type="checkbox"/> End User <input type="checkbox"/> OEM <input type="checkbox"/> Other <input type="checkbox"/>	Website: _____

CYLINDER SPECIFICATIONS

<input type="checkbox"/> AIR CYLINDER - Indicate <u>Working Pressure</u> : _____ <input type="checkbox"/> HYDRAULIC CYLINDER If Hydraulic - Indicate <u>Working Pressure</u> : _____ If Hydraulic - Indicate <u>Maximum Rated Pressure</u> : _____ If Hydraulic - Indicate <u>Fluid Type</u> : _____ (necessary because some Hydraulic Fluids destroy Seals) <input type="checkbox"/> OTHER - Describe: _____	BORE Size: _____ STROKE Length: _____ MOUNTING STYLE: _____ PISTON ROD DIAMETER: _____ PISTON ROD THREADS: Male <input type="checkbox"/> Female <input type="checkbox"/> Other <input type="checkbox"/> (describe Piston Rod Threads): _____ Does the Cylinder have CUSHION(s)? Yes <input type="checkbox"/> No <input type="checkbox"/> If Yes: FRONT END CAP <input type="checkbox"/> REAR END CAP <input type="checkbox"/>
---------------------------------------------------------------------------------------------------------------------------------------------------------------------------------------------------------------------------------------------------------------------------------------------------------------------------------------------------------------------------------------------------------------------------------	-------------------------------------------------------------------------------------------------------------------------------------------------------------------------------------------------------------------------------------------------------------------------------------------------------------------------------------------------------------------------------------------------------------------------------------------------

What is the Work Being Performed?

Weight of Load moved: on Extend: _____ lbs. on Retract: _____ lbs. on BOTH Extend & Retract: _____ lbs.
 Cylinder Cycle Rate: _____ Cycles per Minute _____ Cycles per Hour _____ Cycles per Day
 Rod Speed: Extending _____ "/sec. Retracting _____ "/sec. How many days per week will this cylinder operate? _____

What is the Cylinder Orientation?

Cylinder is Mounted: Vertically Rod Up Rod Down Angle Degrees: from Vertical _____ from Horizontal _____
 Is Cylinder Piston Rod or Load Guided or Supported? Yes No (if Yes, explain) _____
 Is Side Load Present? Yes No (if Yes, explain) _____ Side Load Weight: _____ lbs.

What are the Environmental Conditions that the Cylinder is Subjected to?

What is the present Cylinder Type & Model Number if applicable? _____
 Temperature at the Cylinder (if applicable) is _____ Degrees F. Is the temperature constant? Yes No
 What is the variable temperature range (if applicable)? from: _____ Minimum Degrees F to _____ Maximum Degrees F.
 Cylinder Environment conditions: Corrosive Chemicals present Abrasives present Water present Outdoors
 Other (please explain): _____

What is the Application or Special Requirements?

Are there any optional features applicable to this cylinder? Yes No If yes, please explain: _____
 What industry is the cylinder used in? _____
 What type of machine is the cylinder used on? _____
 What is the present problem/failure mode? _____

Is a Cylinder ACCESSORY Required? (ex. a Rod Clevis) : No Yes (indicate the type of Accessory _____ & provide Dimensions on Page 10)

**Describe Application and/or Draw a Sketch of the Cylinder Within the Application.
Draw any Special Features Contained on this Cylinder (attach drawing if necessary)**
