

How to Order and Specify

Example: Model IMH Metric Heavy-Duty, Steel Air Cylinder

STEEL CONSTRUCTED CYLINDER: Detachable Front Angle Foot Mount (MS1), 80 mm Bore, 100 mm Stroke, 25 mm Piston Rod Diameter with M20 x 1.50 - 40 Male Rod End Threads. Both the Front & Rear End Caps have a Turck Proximity Switch (with mini connector) affixed by Peninsular to the cylinder heads at Position #1, Cushion Adjustment Screw at Position #2, BSPP air supply port (G-Port) at Position #3, Nothing at Position #4. This cylinder is equipped with a "Slip Tuff" specially coated rod cartridge as an optional feature in Position **J** because of severe side loaded operating conditions.

1 2 3 4
IMH 13 80 x 100 AM - SCGN - SCGN - T11 /Z
 Position No. **A B C D E F G H J**

1 2 3 4
SCGN - SCGN - T11 /Z
 Position No. **F G H J**

A Cylinder Model: Specify **IMH** in this position.

- | | |
|--|---|
| <ul style="list-style-type: none"> ■ 32 mm Bore through 320 mm Bore ■ Bolt on Cylinder Mounts (Standard) ■ Longer lasting improved Nitrile Seals Standard). Viton high temperature & other seal materials (Optional) ■ Internally lubricated for life; no in-line lubrication required (Standard) ■ Removable, internally lubricated, Bearing Cartridge (Standard). No special tools required. ■ "Slip Tuff" coated Bearing Cartridge for severe side loaded applications (Optional) | <ul style="list-style-type: none"> ■ Machined Steel Cylinder Heads ■ D.O.M Steel Seamless Tube with hard chrome plated ID (Standard) ■ 100,000 PSI yield, IHCP chrome plated piston rod (Standard) ■ Adjustable Cushions with Captive Screw. (Cushion feature is optional) ■ In-Port Cylinder Head mounted "RF" Inductive Proximity Switches, with no spacers underneath the switch, for near end of stroke piston position sensing (Optional). These replace mechanical limit switches. |
|--|---|

B Specify Cylinder Mounting Style: See below illustrations

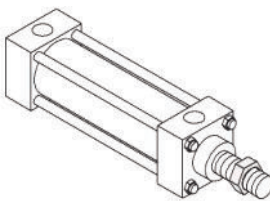
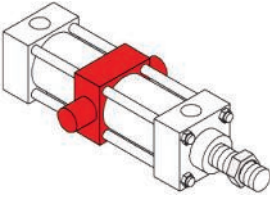
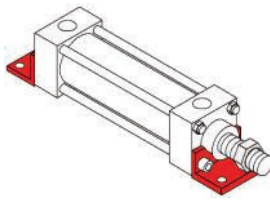
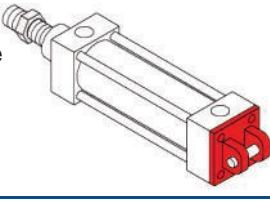
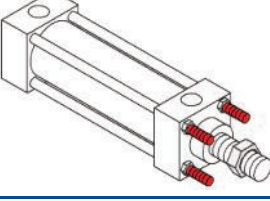
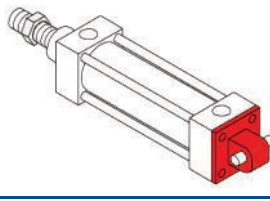
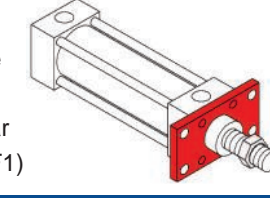
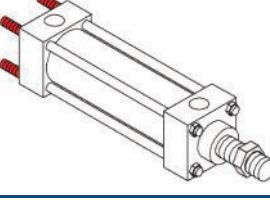
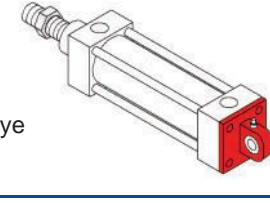
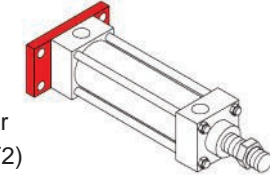
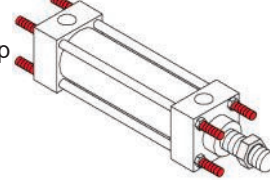
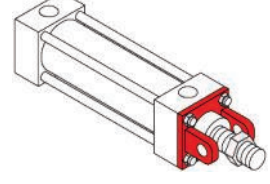
IMH 0 No Mount (MX0) 	IMH 6 Center Trunnion (MT4) 	IMH 13 Detachable Front Angle Foot Mount (MS1) 
IMH 3 Detachable Rear Clevis (MP2) 	IMH 8 Head Tie Rod Extended (MX3) 	IMH 21 Cap Detachable Eye (MP4) 
IMH 4 Detachable Front Rectangular Flange (MF1) 	IMH 11 Cap Tie Rod Extended (MX2) 	IMH 30 Cap Detachable Spherical Eye (MP6) 
IMH 5 Detachable Rear Rectangular Flange (MF2) 	IMH 12 Head & Cap Tie Rod Extended (MX1) 	IMH 31 Detachable Head Clevis (MP7) 

Note: Specify **XV Dimension** at Position "J" when ordering an Intermediate Trunnion Cylinder (IMH 6). In the absence of an XV Dimension, Peninsular will center the Intermediate Trunnion between the two end caps.

C Specify Cylinder Bore :

32 = 32 mm Bore	125 = 125 mm Bore
40 = 40 mm Bore	160 = 160 mm Bore
50 = 50 mm Bore	200 = 200 mm Bore
63 = 63 mm Bore	250 = 250 mm Bore
80 = 80 mm Bore	320 = 320 mm Bore
100 = 100 mm Bore	

D Specify Stroke Length:

Specify Stroke Length in millimeters from 25 mm to 3,000 mm.

For Stop Spool (StopTube) applications, contact Peninsular to determine "call out" for the correct stroke length to specify.

E Specify Piston Rod Diameter & Piston Rod Thread Size:

First letter denotes - the Rod Diameter,
Specify: "A" for the Standard Metric Rod Diameter

Second letter denotes - the Rod Thread Size,
Specify: "M" for the Standard Metric Rod Thread Size

For Thread Sizes other than Standard,
Specify: "X" and describe

Bore Size	Standard Rod Diameter Specify "A"	Standard Male Rod Threads Specify "M"
32 mm	12 mm	M10 x 1.25 - 22 LONG
40 mm	16 mm	M12 x 1.25 - 24 LONG
50 mm	20 mm	M16 x 1.50 - 32 LONG
63 mm	20 mm	M16 x 1.50 - 32 LONG
80 mm	25 mm	M20 x 1.50 - 40 LONG
100 mm	32 mm	M20 x 1.50 - 40 LONG
125 mm	32 mm	M27 x 2.00 - 54 LONG
160 mm	40 mm	M36 x 2.00 - 72 LONG
200 mm	40 mm	M36 x 2.00 - 72 LONG
250 mm	50 mm	M42 x 2.00 - 84 LONG
320 mm	50 mm	M48 x 2.00 - 96 LONG

F-G Specify Plumbing Configuration for Front End Cap (F) & Rear End Cap (G)

For any cylinder mount, always view the Cylinder through the Front End Cap when determining Side Locations for Ports and the Cushion Adjustment Screw.

N = Nothing. No Air Supply Port, No Cushion Adjustment Screw or Proximity Switch Mounting Boss.
A = Air Supply Port - NPT Threads
G = BSPP Air Supply Port (G-Port) is Standard
W = BPT Air Supply Port
S = In-Port, cylinder head mounted, Proximity Switch will be affixed by Peninsular to the cylinder head. (Complete Position H.)
M = Cylinder Head will be precision machined to receive an "In Port" mounted Proximity Switch to be installed by the customer.
C = Cushion Adjustment Screw
B = NPT port and Cushion adjustment screw at same side location
V = BSP (G-Port) and cushion adjustment screw on same side location
Q = BPT port and cushion adjustment screw on same side location

End Cap Side Positions

Below is a Center Trunnion (MT4) showing both the Front & Rear End Caps with Air Supply Ports at Positions #1

Arrows point to the End Cap Side Positions

H Optional Proximity Switches (If no switch is required, specify "O" in Position H)

CYLINDER HEAD MOUNTED PROXIMITY SWITCHES (RF Inductive Proximity Switches) are In-Port Mounted to a precision machined surface on either or both Cylinder End Caps

Specify Switch Type

X-B11 = Balluff - Mini-Connector	T-11 = Turck Mini-Connector
X-B31 = Balluff - Micro-Connector	T-31 = Turck Micro-Connector

Other Cylinder Head Mounted Proximity Switches are also available - Topworx, Namco, Pepperl & Fuchs, etc.
Proximity Switch Cordsets are available in various lengths - contact Peninsular for Ordering Information.

RF Inductive (Cylinder Head Mounted) Proximity Switch Probe Length Dimensions (both End Caps without Spacers)										
Bore Size	40 mm	50 mm	63 mm	80 mm	100 mm	125 mm	160 mm	200 mm	250 mm	320 mm
Probe Length	1.025"	1.025"	1.025"	1.025"	1.250"	2.062"	2.062"	2.875"	3.775"	4.562"

J Specify Optional Features with Slash Mark & Alpha (Characters)

/EExtended Piston Rod *	/NStop Tube *	/XVSpecify XV Dimension (IMH 6) *
/FBronze Rod Cartridge	/R ...Threaded Stud, Piston Rod End	/YDouble Rod End
/HRod Boot Cover	/SScraper Ring	/Z "Slip Tuff" Coated Rod Cartridge
/JSpring Extend	/UNon-Rotatable Piston Rod	/OOther Options (Describe)
/KSpring Return	/VViton Seals	

* = Specify Length

Model *IMH* - Metric Air Cylinder Accessories

(must be ordered separately)

Bore	Rod Thread	Standard Rod Clevis (with Pin Attached)		Rod Alignment Coupler	Coupling Plate		Coupling Plate Nut	
		Part #	NAAMS #	Part #	Part #	NAAMS #	Part #	NAAMS #
32	M10 x 1.25	IF32-77	A660310	IF100-79	IF32-80	A710014	IF32-81	A721014
40	M12 x 1.25	IF40-77	A660412	IF120-79	IF32-80	A710014	IF40-81	A721214
50 & 63	M16 x 1.50	IF50-77	A660516	IF160-79	IF50-80	A710020	IF50-81	A721620
80 & 100	M20 x 1.50	IF80-77	A660820	IF200-79	IF50-80	A710020	IF80-81	A722020
125	M27 x 2.00	IF125-77	A661227	IF270-79	IF125-80	A710025	IF125-81	A722725
160 & 200	M36 x 2.00	IF160-77	A661636	IF360-79	IF125-80	A710025	IF160-81	A723625
250	M42 x 2.00	IF250-77	A662542	IF420-79	IF250-80	A710033	IF250-81	A724233
320	M48 x 2.00	IF320-77	A663248	-	-	-	-	-



Standard Rod Clevis (with Pin Attached)
-77 Model



Rod Alignment Coupler
-79 Model



Coupling Plate with Nut
-80 & 81 Models



Male Eye Bracket (used with Detachable Rear Clevis Mount - MP2)
-76 Model



Trunnion Mounting Block
-91 Model

Bore	Pin Diameter	Male Eye Bracket (used with Detachable Rear Clevis Mount - MP2)		Clevis Pin (used with Detachable Rear Clevis Cylinder Mount - MP2)		Trunnion Mounting Block
		Part #	NAAMS #	Part #	NAAMS #	Part #
32	10	IF32-76	A611032	IF32-66	A643264	IF40-91
40	12	IF40-76	A611240	IF40-66	A644076	IF40-91
50	12	IF50-76	A611250	IF50-66	A645085	IF40-91
63	16	IF63-76	A611663	IF63-66	A646395	IF63-91
80	16	IF80-76	A611680	IF80-66	A648011	IF63-91
100	20	IF100-76	A612010	IF100-66	A641013	IF100-91
125	25	IF125-76	A612512	IF125-66	A641216	IF100-91
160	30	IF160-76	A613016	IF160-66	A641620	IF160-91
200	30	IF200-76	-	IF200-66	-	IF160-91
250	40	IF250-76	-	IF250-66	-	IF250-91
320	45	IF320-76	-	IF320-66	-	IF320-91

Model *IMH* - Metric Air Cylinder Seal & Repair Kits

(must be ordered separately)

Bore Size	Rod Diameter	Complete Cylinder Seal Kits		Complete Cylinder Repair Kits		Rod Cartridge Repair Kits	
		Standard Seals	Viton Seals	Standard Seals	Viton Seals	Standard Seals	Viton Seals
32	12 Std.	SKM1032	SKM1032V	RKM1032	RKM1032V	CKM1032	CKM1032V
40	16 Std.	SKM1040	SKM1040V	RKM1040	RKM1040V	CKM1040	CKM1040V
50	20 Std.	SKM1050	SKM1050V	RKM1050	RKM1050V	CKM1050	CKM1050V
63	20 Std.	SKM1063	SKM1063V	RKM1063	RKM1063V	CKM1063	CKM1063V
80	25 Std.	SKM1080	SKM1080V	RKM1080	RKM1080V	CKM1080	CKM1080V
100	32 Std.	SKM1100	SKM1100V	RKM1100	RKM1100V	CKM1100	CKM1100V
125	32 Std.	SKM1125	SKM1125V	RKM1125	RKM1125V	CKM1125	CKM1125V
160	40 Std.	SKM1160	SKM1160V	RKM1160	RKM1160V	CKM1160	CKM1160V
200	40 Std.	SKM1200	SKM1200V	RKM1200	RKM1200V	CKM1200	CKM1200V
250	50 Std.	SKM1250	SKM1250V	RKM1250	RKM1250V	CKM1250	CKM1250V
320	50 Std.	SKM1320	SKM1320V	RKM1320	RKM1320V	CKM1320	CKM1320V

Complete Cylinder Seal Kit includes: (1) Rod Wiper Seal, (1) Rod Seal, (1) Rod Bearing Cartridge O-Ring Seal, (2) Piston U-Cup Seals, (2) Cushion Seal Inserts, (2) End Cap to Tube O-Ring Seals, (2) Cushion Screw O-Ring Seals & (1) Tube of Lubricating Grease

Complete Cylinder Repair Kit includes: all of the seals in the **Complete Cylinder Seal Kit** plus (1) Rod Bearing Cartridge

Rod Bearing Cartridge Kit includes: (1) Rod Bearing Cartridge, (1) Rod Wiper Seal, (1) Rod Seal, (1) Rod Bearing Cartridge O-Ring Seal & (1) Tube of Lubricating Grease