

NFPA Clevis Bracket

Model - 78

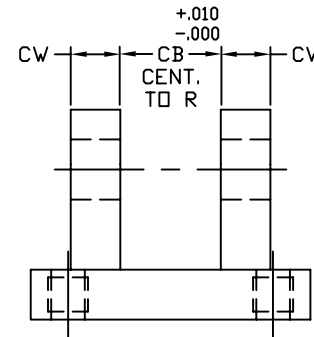
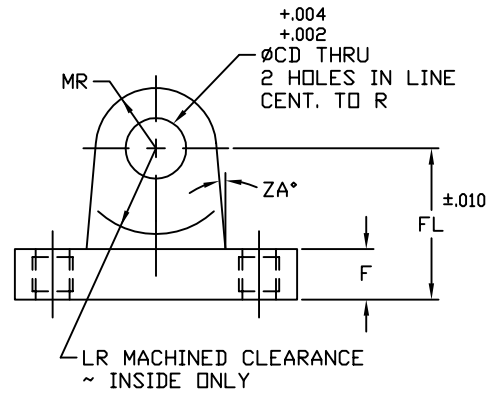
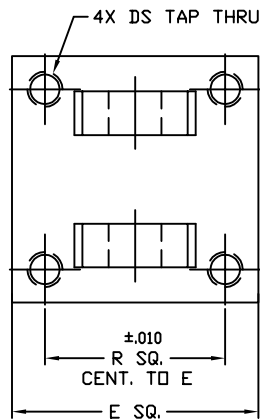
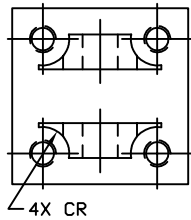

8.05

C1200-78

C1150-78

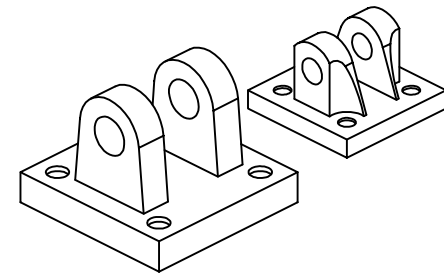

PART No.	CB	CD	CR	CW	DS	E	F	FL	LR	MR	R	ZA
C1150-78	.765	.500	.375	.500	3/8-24	2.500	.375	1.125	.500	.562	1.625	20°
C1200-78	1.265	.750	-	.625	1/2-20	3.500	.625	1.875	1.062	1.062	2.562	5°
C1400-78	1.515	1.000	.562	.750	5/8-18	4.500	.750	2.250	1.250	1.125	3.250	5°
C1600-78	2.031	1.375	.562	1.000	5/8-18	5.000	.875	3.000	1.875	1.750	3.812	5°
C1800-78	2.531	1.750	.750	1.250	7/8-14	6.500	.875	3.125	2.000	1.875	4.938	5°
C1900-78	2.531	2.000	.844	1.250	1-14	7.500	1.000	3.500	2.125	2.125	5.750	5°
C1901-78	3.031	2.500	.938	1.500	1 1/8-12	8.500	1.000	4.000	2.625	2.500	6.594	5°
C1902-78	3.031	3.000	1.031	1.500	1 1/4-12	9.500	1.000	4.250	2.875	2.750	7.500	5°
C1904-78	4.031	3.500	1.406	2.000	1 3/4-12	12.625	1.688	5.688	3.625	3.500	9.625	5°
C1906-78	4.531	4.000	-	2.250	2-12	14.875	1.938	6.438	4.000	4.000	11.500	5°
C1908-78	6.031	5.000	2.000	3.000	2 1/2-12	17.125	2.188	7.688	5.000	5.000	13.000	5°