

HEAD TIE ROD EXTENDED

Peninsular
Mounting Style: **HP 8**

Heavy Duty Hydraulic Cylinder • 3000 P.S.I. Working Pressure • 5000 P.S.I. Rated Pressure

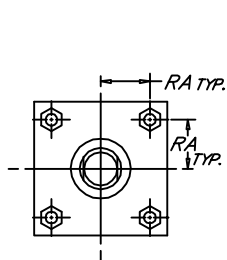
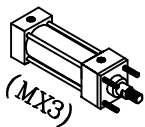

8" BORE

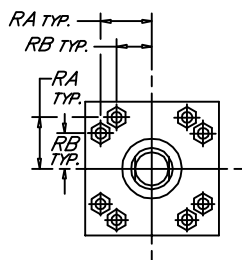

10" & 12" BORES

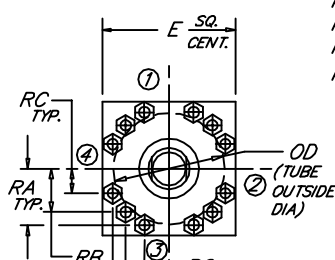

14" BORE

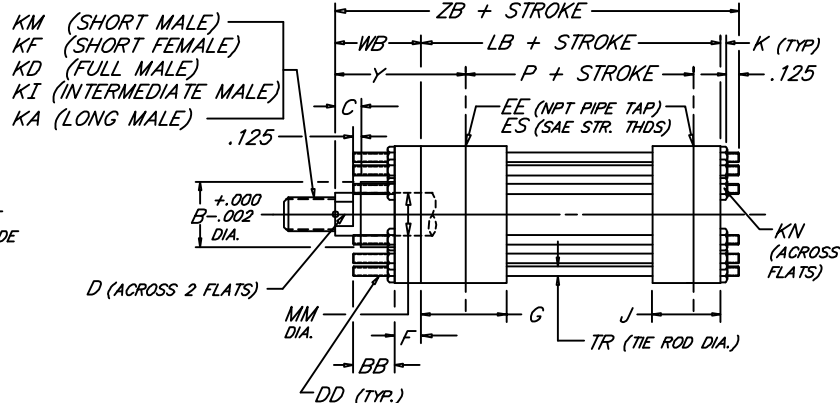

BORE	ROD					ROD THREAD X LENGTH																	NPT/SAE									
	MM	KM & KF	KD	KI	KA	B	BB	C	D	DD	E	EE	ES	F	G	J	K	KN	LB	P	OD	RA	RB	RC	TR	WB	Y	ZB				
8.000	3.500	2 1/2"-12 x 3.500	3 1/2"-12 x 3.500	3 1/4"-12 x 3.500	3 1/4"-12 x 6.500	4.249			3.000																							
	4.000	3"-12 x 4.000	4"-12 x 4.000	3 3/4"-12 x 4.000	3 3/4"-12 x 7.500	4.749			3.375																							
	4.500	3 1/4"-12 x 4.500	4 1/2"-12 x 4.500	4 1/4"-12 x 4.500	4 1/4"-12 x 8.250	5.249	4.500	1.000	3.875	1 1/4"-12	9.500	1 1/2	-24	1.000	3.000	3.000	1.188	1.844	9.500	6.125	9.250	3.750	---	---	1.250	2.250	3.938	13.063				
	5.000	3 1/2"-12 x 5.000	5"-12 x 5.000	4 3/4"-12 x 5.000	4 3/4"-12 x 9.000	5.749			4.250																							
	5.500	4"-12 x 5.500	5 1/2"-12 x 5.500	5 1/4"-12 x 5.500	5 1/4"-12 x 10.000	6.249			4.625																							
10.000	4.500	3 1/4"-12 x 4.500	4 1/2"-12 x 4.500	4 1/4"-12 x 4.500	4 1/4"-12 x 8.250	5.249			3.875																							
	5.000	3 1/2"-12 x 5.000	5"-12 x 5.000	4 3/4"-12 x 5.000	4 3/4"-12 x 9.000	5.749			4.250																							
	5.500	4"-12 x 5.500	5 1/2"-12 x 5.500	5 1/4"-12 x 5.500	5 1/4"-12 x 10.000	6.249	4.125	1.000	4.625	1 1/8"-12	12.625	2	-32	1.250	3.688	3.688	1.094	1.656	12.125	8.500	11.750	5.291	3.775	---	1.125	3.187	5.000	16.531				
	6.000	4 1/2"-12 x 6.000	6"-12 x 6.000	5 3/4"-12 x 6.000	5 3/4"-12 x 10.000	6.749			5.125																							
	7.000	5"-12 x 7.000	7"-12 x 7.000	6 1/2"-12 x 7.000	6 1/2"-12 x 10.000	7.749			6.000																							
12.000	5.500	4"-12 x 5.500	5 1/2"-12 x 5.500	5 1/4"-12 x 5.500	5 1/4"-12 x 10.000	6.249			4.625																							
	6.000	4 1/2"-12 x 6.000	6"-12 x 6.000	5 3/4"-12 x 6.000	5 3/4"-12 x 10.000	6.749			5.125																							
	7.000	5"-12 x 7.000	7"-12 x 7.000	6 1/2"-12 x 7.000	6 1/2"-12 x 10.000	7.749	4.500	1.000	6.000	1 1/4"-12	14.875	2 1/2	-32	1.500	4.438	4.438	1.188	1.844	14.500	10.125	14.000	6.270	4.555	---	1.250	3.437	5.625	19.250				
	8.000	5 3/4"-12 x 8.000	8"-12 x 8.000	7 1/2"-12 x 8.000	7 1/2"-12 x 12.000	8.749			7.000																							
14.000	7.000	5"-12 x 7.000	7"-12 x 7.000	6 1/2"-12 x 7.000	6 1/2"-12 x 10.000	7.749			6.000																							
	8.000	5 3/4"-12 x 8.000	8"-12 x 8.000	7 1/2"-12 x 8.000	7 1/2"-12 x 12.000	8.749			7.000																							
	9.000	6 1/2"-12 x 9.000	9"-12 x 9.000	8 1/2"-12 x 9.000	8 1/2"-12 x 13.500	9.749	4.500	1.000	7.875	1 1/4"-12	17.125	3	-32	1.938	4.875	4.875	1.188	1.844	15.625	10.875	16.000	7.485	6.143	4.409	1.250	3.437	5.625	20.375				
	10.000	7 1/4"-12 x 10.000	10"-12 x 10.000	9 1/2"-12 x 10.000	9 1/2"-12 x 15.000	10.749			8.625																							

NEVA DESIGN

FILE: HPOBL2.dwg REV: 12-21-06