

# METRIC TRUNNION MOUNTING ASSEMBLY

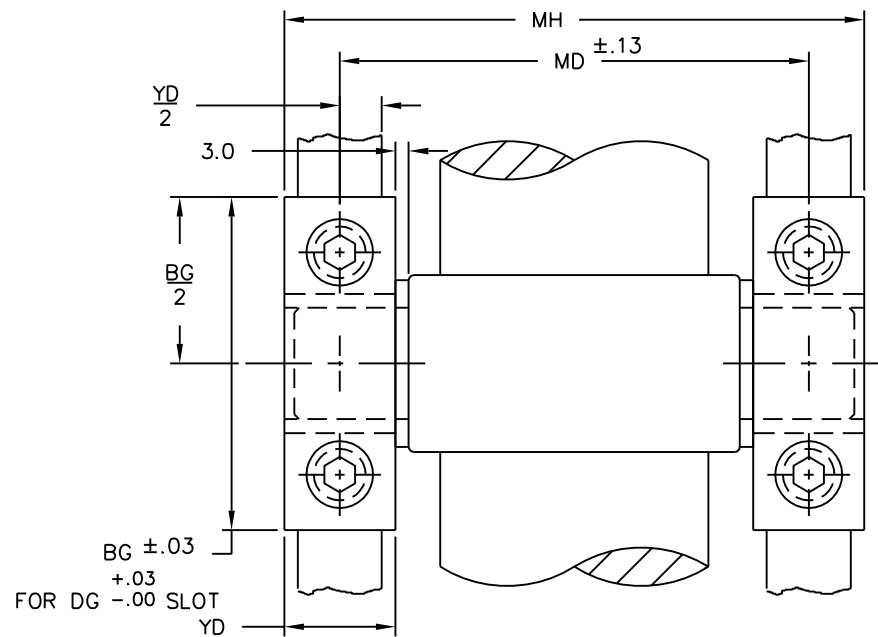
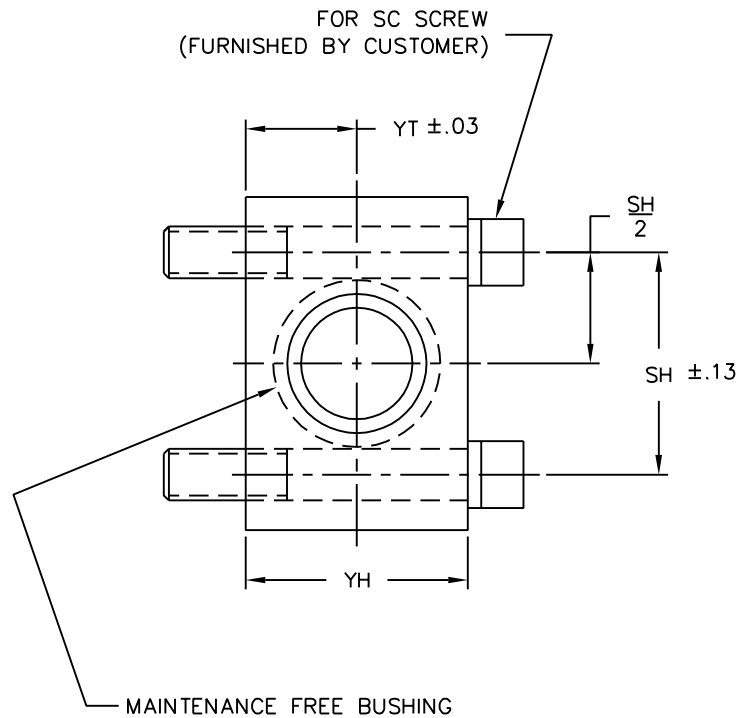

CENTER TRUNNION CYLINDER WITH TWO (2) METRIC TRUNNION MOUNTING ASSEMBLIES.

CYL. BORE	ORDER NO.	BG	DG	MD	MH	SC	SH	YD	YH	YT
40 MM	IF40-91N	55.00	55.06	87.00	105	M8	36.00	18	36	18.00
50 MM	IF40-91N	55.00	55.06	99.00	117	M8	36.00	18	36	18.00
63 MM	IF63-91N	65.00	65.06	116.00	136	M10	42.00	20	40	20.00
80 MM	IF63-91N	65.00	65.06	136.00	156	M10	42.00	20	40	20.00
100 MM	IF100-91N	75.00	75.06	164.00	190	M12	50.00	26	50	25.00
125 MM	IF100-91N	75.00	75.06	192.00	218	M12	50.00	26	50	25.00
160 MM	IF160-91N	92.00	92.06	243.00	280	M16	60.00	37	60	30.00
200 MM	IF160-91N	92.00	92.06	293.00	330	M16	60.00	37	60	30.00
250 MM	IF250-91N	140.00	140.06	379.00	432	M20	90.00	53	70	35.00

If the recommended "DG" slot cannot be provided, another means of stopping the Metric Trunnion Assembly from moving with the push/pull forces of the cylinder MUST be utilized. The Metric Trunnion Mounting Assembly should NEVER be rotated 90° from the position in the above drawing, because loosening of the mounting screws will occur as a result of the push/pull cylinder forces.

## PENINSULAR® CYLINDER COMPANY

27650 Groesbeck Highway Roseville Michigan 48066-2759 Telephone: 586-775-7211 Fax: 586-775-4545  
 Toll Free: 800-526-7968 Internet: <http://www.peninsularcylinders.com> Email: [sales@peninsularcylinders.com](mailto:sales@peninsularcylinders.com)

REV. 14 JAN 2003

